



Congratulations on the purchase of your new Prince Table Tennis table. Our products are designed and manufactured to give you years of game playing enjoyment.

*KEEP BOX AND PACKING MATERIAL UNTIL TABLE HAS BEEN COMPLETELY ASSEMBLED.*

*ALL DAMAGE MUST BE REPORTED TO DMI WITHIN TEN DAYS OF RECEIPT.*

*If you have any problems with your new product,*

**PLEASE DO NOT RETURN IT TO THE STORE.**

Please contact us:

**1.800.399.4402**

**FAX: 215.283.9573**

Please have your model number when inquiring about parts.

Or write to:

DMI Sports

Customer Service

1300 Virginia Drive, Suite 401

Fort Washington PA, 19034

Please visit our web site at:

**[www.dmisports.com](http://www.dmisports.com)**

When contacting DMI Sports, please provide your model number and item number (if applicable) if requesting a replacement part.

Item numbers can be found inside this owners manual.

Your Model Number PT701

**Your model number is also located on the original carton. These instructions are also available online at: [www.dmisports.com](http://www.dmisports.com).**

# IMPORTANT!

**Please Keep Your Instructions!** (You will need your Model number should you need to contact us.) Before attempting assembly, please read through this instruction book to familiarize yourself with all the parts and assembly steps. We recommend that two adults assemble this table. Please refer to the Parts Identifier on the following page and be sure that all parts have been included. Although extremely rare, occasionally a part may be missing. If you are missing a part, or if you have any questions, please call our customer service department at 1.800.399.4402 Mon-Fri between the hours of 9:00am and 5:00pm E.S.T; or you can reach us at: [www.dmisports.com](http://www.dmisports.com).

Do not return the game to the store. Please contact us first at: 1.800.399.4402 or on our website at: [www.dmisports.com](http://www.dmisports.com).

## TWO ADULTS ARE REQUIRED TO ASSEMBLE THIS TABLE TENNIS TABLE



















**TOOLS REQUIRED FOR ASSEMBLY:**

- Screwdriver- Not Included
- Wrench Set - Not Included

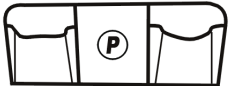
**PARTS IDENTIFIER**

**ASSEMBLY PARTS**

P1	Qty. 4	P2	Qty. 2	P3	Qty. 4	P4	Qty. 6
							
Caster with lock		Gravity lock		Metal bracket		Bushing	
P5	Qty. 2	P6	Qty. 2	P7	Qty. 8	P8	Qty. 8
							
Linkage tube with stop bracket		Linkage tube		6 x 75 mm hex head bolt		6 x 60 mm hex head bolt	
P9	Qty. 18	P10	Qty. 24	P11	Qty. 38	P12	Qty. 2
							
6mm locking nut		4 x 12mm hex head screw		6mm washer		short "U" style leg	
P13	Qty. 1	P14	Qty. 2	P15	Qty. 2	P16	Qty. 2
							
Net post set		T.T. paddles holder bags		1.5" Outereg		1.5" Inner LE	
P17	Qty. 2	P17	Qty. 2				
							
Table half		Safety strap					

# ASSEMBLY INSTRUCTIONS

We recommend that at least two strong adults work together to assemble this table.

- The table will be assembled upside down and then turned over onto its legs. This is a very heavy table and turning it over will require at least two strong adults.
- We suggest that you use the bottom carton as a clean flat work area to protect the table

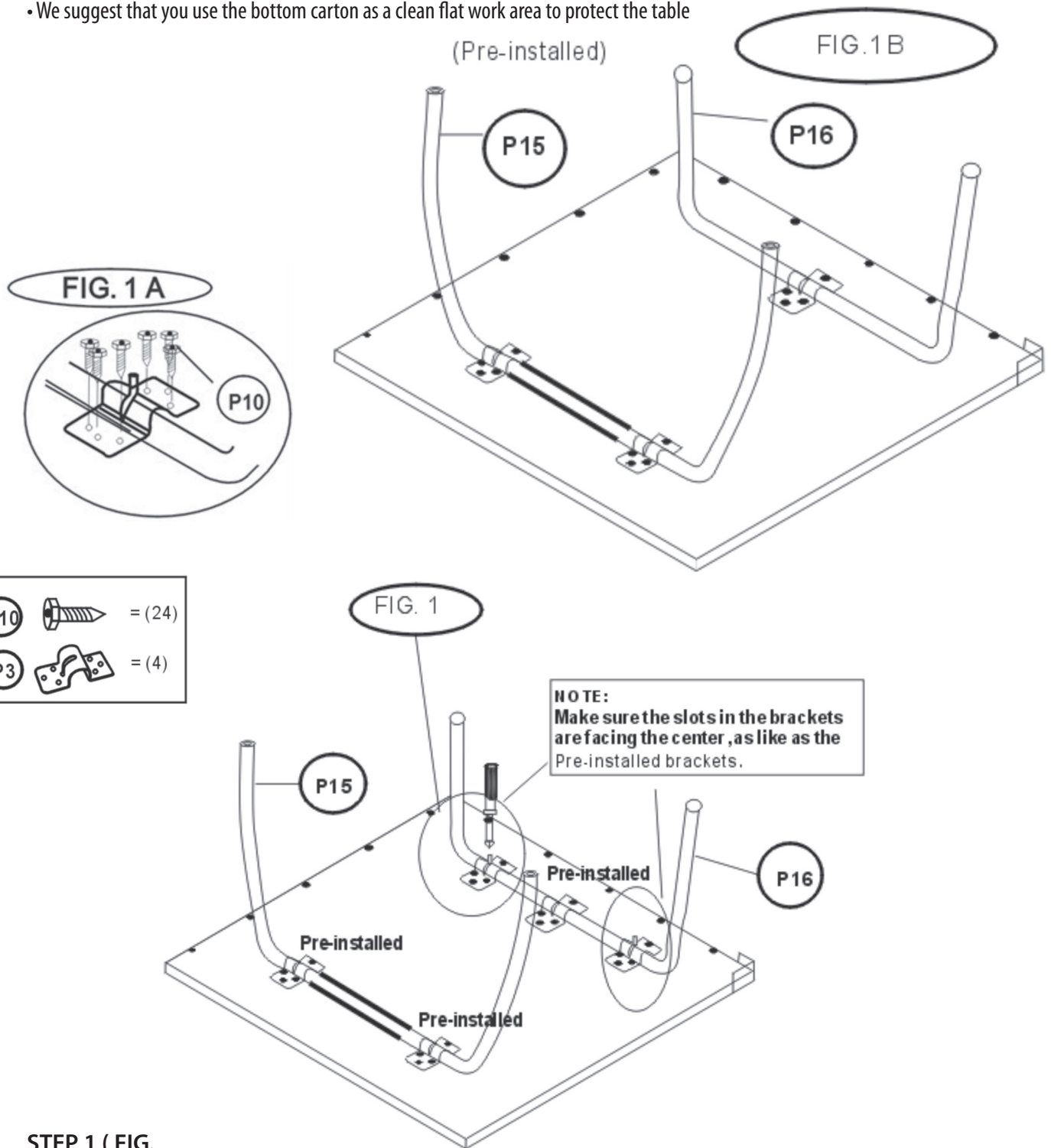

## STEP 1 ( FIG.

- Make sure the Pre-installed Metal Brackets ( #P3) are attached over the Outer Leg (#P15)and Inner Leg (#16).
- Attached the two Metal Brackets (#P3) over the ends of the Inner Leg (#P16) using six Screws (#P10) per bracket .See Fig. 1 and Fig.1 A.  
**NOTE:** Make sure the slots in the brackets are facing the center.
- Repeat the above steps for the other table half.

## STEP 2 ( FIG. 2 )

- Attach one end of the Linkage Tube(#P6) on the inside of the Outer Leg (#P15) and the other end of the Linkage Tube to the outside of the Inner Leg (#P16) using one Bolt (#P8),two washers (#P11),one Bushing (#P4) and one Locking Nut (#P9) in the order shown in Fig.2.
- Attach one of the Linkage Tube with stop bracket(#P5) to the inside of the Outer Leg(#P15) using one Bolt(#P8), three Washers(#P11) and one Nut (#P9). See Fig.2.  
**NOTE:** Do not use a Bushing when attaching the Linkage Tube with Stop Bracket (#P5).See Fig. 2.
- Place one Caster with Lock (#P1) into each Inner Leg (#P16).
- Repeat the above steps for the other table half.

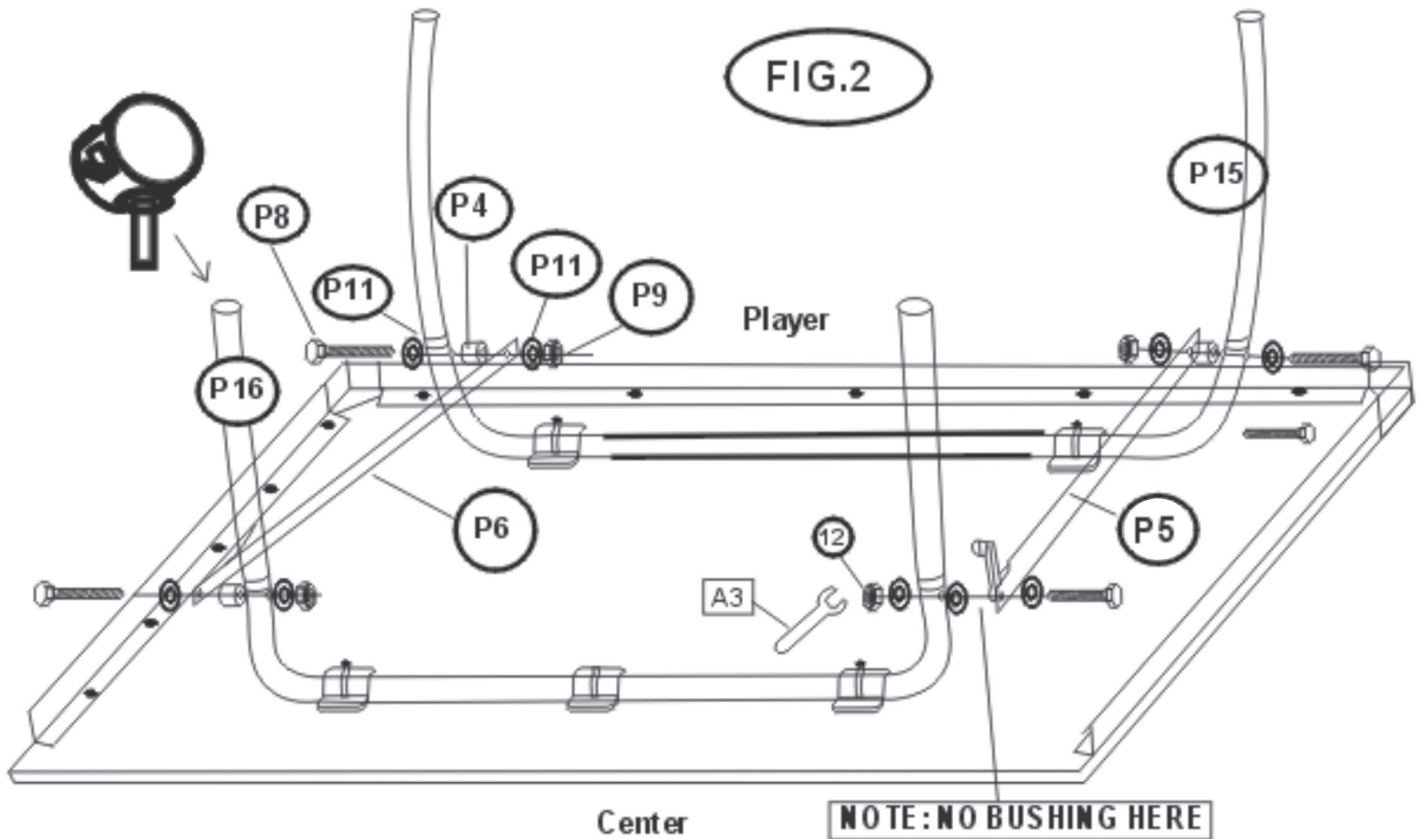

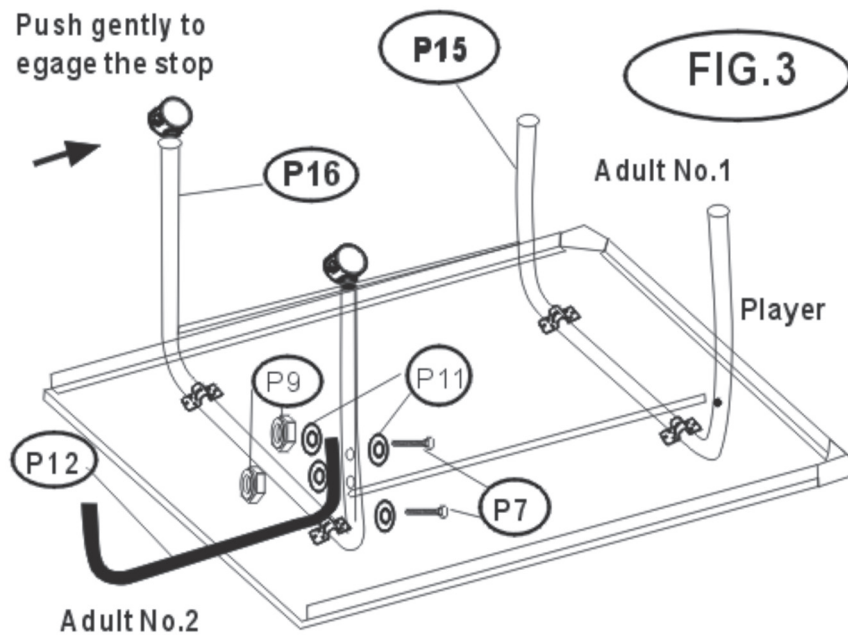

**STEP 3 ( FIG. 3 )**

- Attach one Short “U” Style Leg (#P12) to the Inner Leg (#P16) with two Bolt(#P7), four Washers(#P11) and two Nut (#P9) per Short “U” Style Leg. See Fig. 3. Repeat the step for other side.
- Before turning the table over, make sure to push the Inner Leg (#P16) towards the player end of the table in order to engage the table stop.
- At least two strong adults are required to turn this table over.
- Do not let the table rest on its side or its legs, or this may damage the table.
- One person should stand at each end of the table and turn the table over completely so that it rests on its legs. See Fig. 3 and 4.
- Repeat the above steps for the other table half.

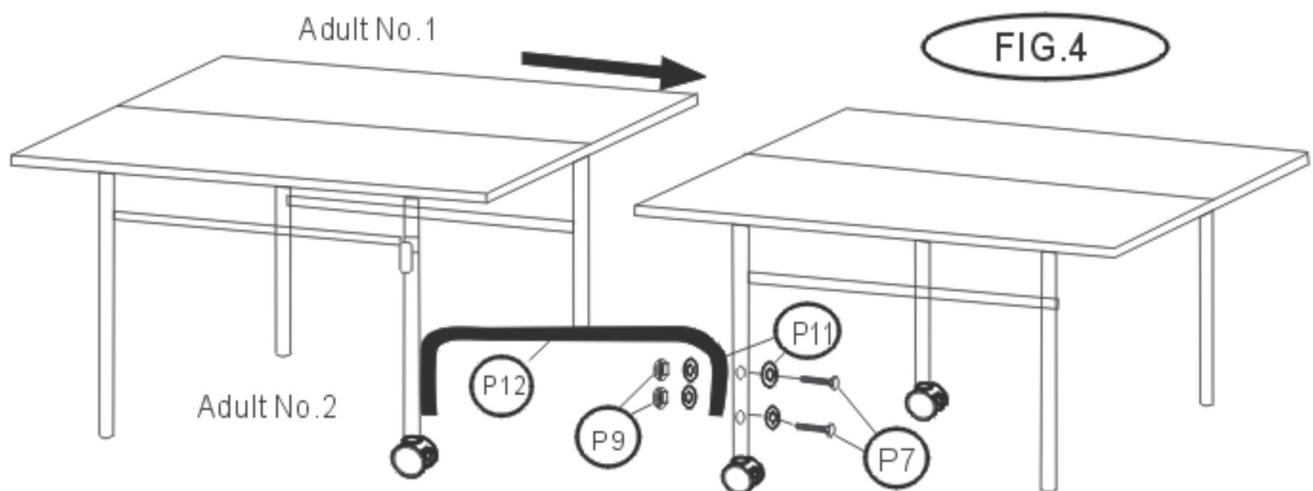

**STEP 4 ( FIG. 4 )**

- Standing at the sides of the table ,place the two table halves, so they are inches apart  
**NOTE:** Be careful that you do not push either half backwards as this may cause the legs to fold.
- Attach the Short “U” style Leg (#P12) to Inner Leg (#P16) on the opposite table half using two Bolt (#P7) four Washers (#P11) and two Locking Nut (#P9) as shown in Fig.5. Repeat the above steps for the other side.

### STEP 5 ( FIG. 5 )

- Attach the Gravity Lock (#P2) to the Inner Leg (#P16) with two Washers (#P11) and one Nut (#P9) per Gravity Lock. See Fig.5. And Fig.5 A.
- Repeat the above step for the other side.
- Attach the two T.T.Paddles holder bags (#P14) onto each Short "U" Style Leg (#P12).

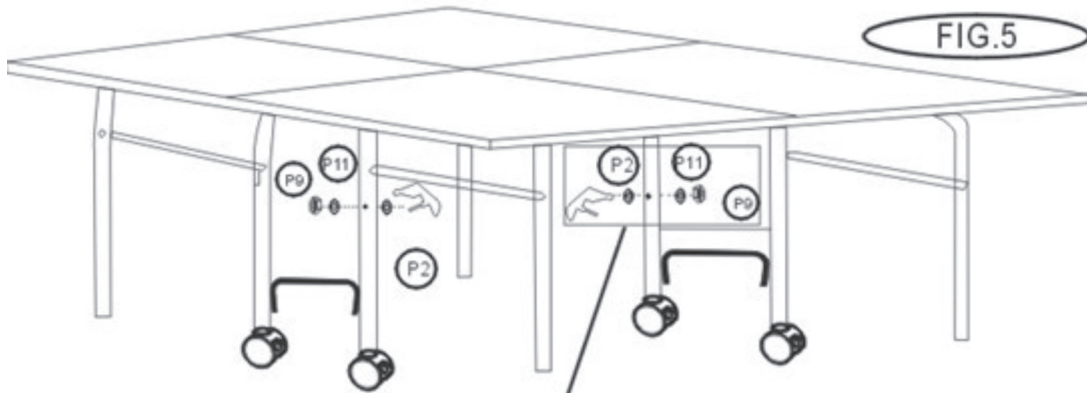
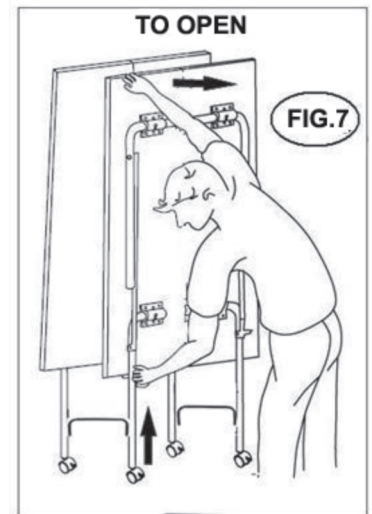
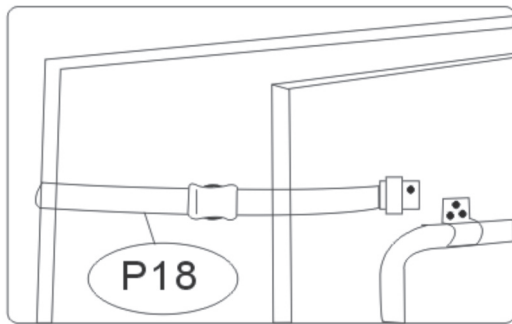

FIG.6



### **WARNING!**

- This is a very heavy table, do please close the Safety Strap (#P16) while the table is closed. See Fig.6.
- To close the table: Raise the end of the table without the net post and close the legs until the Gravity Lock Latches onto the table.
- To open the table: Release the safety strap and raise the gravity lock. See Fig.7.
- This is not a child's toy. Adult supervision is required for children playing this game. Please read this instruction carefully. Proper use of this set can avoid damage or injury.
- **FOR INDOOR USE ONLY.**



## RECOMMENDATION OF USE AND PRECAUTIONS

Anyone using or handling this table tennis table must always follow the illustrated instructions attached to the back of the board and be fully aware of the operation instructions.

1. Handling the table, (Assembly, open, close or to store) should always be done by two adults to prevent accident or injury.
2. Be sure that no persons or objects are in the way of the boards when opening the table.
3. Do not put heavy objects on the table.
4. Do not sit on the table.
5. Do not clean the table with solvents or any other aggressive product because it could damage the paint finish.
6. Do not use sharp objects on the board or painter surface.
7. If the table is used for purposes other than playing table tennis, cover the surface to prevent any damage.
8. Request proof of purchase and keep it during the warranty period.
9. Under no circumstances is the manufacturer responsible for direct or indirect damages including loses of benefits or any other commercial damage occurred by the use of the purchased product.
10. The functioning and storage of this product should always be supervised by an adult.
11. Do not store or handle the table on an unstable floor surface.
12. If safety device malfunction occurs, secure table tops until the problem is solved.
13. To extend the life of this product, (outdoor table or indoor table) protect it from moisture or severe climate changes.

## Care and Maintenance

### Cleaning your table

Use a soft damp (not wet) cloth only. DO NOT USE ANY CHEMICALS, ABRASIVE OR CLEANING PRODUCTS on the playing surface.

### Maintenance of your table

All moving parts must be oiled including the pivot points. This will insure ease of use and safety of your table.

This table must be stored indoors to avoid damage to the surface. The dampness and temperature changes can cause wood to warp, swell or blister.

## APPLYING LABELS

The very last step in completing the assembly of your new Prince Table Tennis table involves applying the labels to the proper locations on the table. There is one type of label to be applied.

#1 is the Style label. There are 4 labels. Each of the four labels are applied to the four corners of the tables side aprons as shown below.

The labels represented here are not of actual size or color.

**Note:** It is recommended that you write the model number on the under-side of this table for future reference.

